

REMOTE CONTROLLER

RC02-PCR-L

Operation Manual
PCR-W Series Edition

About this manual

We recommend that you read this manual thoroughly beforehand to ensure correct operation of the product. Be sure to store the manual in safe place so that you can use it whenever necessary. When the product is relocated, be sure to the operation manual be included.

All or any parts of this manual may not be reproduced in any forms, without express written permission of Kikusui Electronics Corporation.

The contents of this manual, including the specifications of the instrument, are subject to change without notice.



Copyright© 1996 Kikusui Electronics Corporation

KIKUSUI PART NO. Z1-000-952 IB000831

Printed in Japan.

SAFETY SYMBOLS

The following symbols are indicated where caution is especially required in handling the equipment.

Symbol	Description
	Indicates the existence of a personnel hazard. <ul style="list-style-type: none">• Never fail to follow the operating procedure. Incorrect operating procedures may result in personal injury.• Do not proceed beyond a WARNING sign until the indicated conditions are fully understood and met.
	Indicates the existence of a hazard. <ul style="list-style-type: none">• Always follow the operating procedure. Incorrect operating procedures may damage the equipment or other devices.• Do not proceed beyond a Caution sign until the indicated conditions are fully understood and met.
[Description]	Description and supplement

CONFIGURATION OF THE OPERATION MANUAL

This operation manual is configured as follows:

Chapter 1 GENERAL

Describes the features of the RC02-PCR-L and preparation for use.

Chapter 2 INSTALLATION IN A PCR-W AC POWER SUPPLY

Describes how to install the RC02-PCR-L in a PCR-W AC Power Supply.

Chapter 3 OPERATION CHECK

Describes the operation check that must be conducted before operating the RC02-PCR-L.

Chapter 4 OPERATION METHOD

Describes the operation and functions of the RC02-PCR-L.

Chapter 5 USING A PCR-W² IN THREE PHASE MODE

Describes the functions available in the three-phase mode of the PCR-W² AC Power Supplies that are different from those available in the single-phase mode.

Chapter 6 PART NAMES AND OPERATIONS

Indicates the names of the parts of the RC02-PCR-L and describes these functions of these parts.

Chapter 7 MAINTENANCE

Describes the solutions in the event of a problem. Always read this chapter before requesting a repair.

Chapter 8 SPECIFICATIONS

Shows the specifications of the RC02-PCR-L.

APPENDIX

Shows the hierarchy of the key operation menu.

CONTENTS

SAFETY SYMBOLS	I
CONFIGURATION OF THE OPERATION MANUAL	III
Chapter 1 GENERAL	1-1
1.1 For PCR-W ² Series User	1-2
1.2 Outline	1-2
1.3 Features	1-2
[Description] Regulation adjustment	1-3
1.4 About This Operation Manual and ROM Version	1-3
Chapter 2 INSTALLATION IN A PCR-W AC POWER SUPPLY	2-1
2.1 Check at Unpacking	2-2
2.2 Remote Controller Handling Precautions	2-2
2.3 Installing the Remote Controller Card into a Slot	2-3
2.4 Connecting the Remote Controller Cable	2-4
2.5 Moving Precautions	2-5
2.6 How to Use the Magnet Sheet	2-5
2.7 Quick Reference Card	2-5
Chapter 3 OPERATION CHECK	3-1
3.1 Checking the Initial Setup Status	3-2
[Description] Home Position	3-2
[Description] ENTER Wait	3-3
[Description] LCD (Liquid Crystal Display) Contrast Adjustment	3-3
3.2 Operation Check	3-3
[Description] Back-up data has been lost	3-4
Chapter 4 OPERATION METHOD	4-1
4.1 Basic Operation of the Remote Controller	4-2
4.2 Functions in Common with the PCR-W AC Power Supply	4-3
4.2.1 Functions Whose Key Operation is the Same as That of the PCR-W AC Power Supply	4-3
4.2.2 Functions Whose Key Operation Differs from That of the PCR-W AC Power Supply	4-3
4.3 Functions Extended by Using the Remote Controller	4-4
4.3.1 AC + DC Mode	4-4
4.3.2 Memory Function	4-6
4.3.3 Power, Power-Factor, and Volt-ampere Measurement Mode	4-8
4.3.4 Peak Holding Current Measurement Mode	4-9
[Description] Peak Value and Peak Holding Value Measurements	4-9

4.4 Functions Added by Using the Remote Controller	4-10
4.4.1 Output ON/OFF Phase Setting	4-10
[Description] Removing the RC02-PCR-L after Output ON/OFF phase has been set.	4-11
4.4.2 Regulation Adjustment	4-11
Chapter 5 USING A PCR-W ² IN THREE PHASE MODE	5-1
5.1 Limited Functions	5-2
5.2 Switching between Phase Voltage Display and Line Voltage Display	5-2
5.3 Output Voltage Setting	5-3
5.4 Display of V-/W-Phase Current, V-/W-Phase Voltage, or V-to-W/W-to-U Line Voltage	5-4
5.5 Selecting the Current/Power Display Mode	5-4
5.6 Setting U-to-V or U-to-W Phase Difference	5-5
Chapter 6 PART NAMES AND OPERATIONS	6-1
6.1 Remote Controller Card	6-2
6.2 Remote Controller Box	6-2
Chapter 7 MAINTENANCE	7-1
7.1 Before Requesting a Repair	7-2
Chapter 8 SPECIFICATIONS	8-1
8.1 Specifications	8-2
8.2 Dimensions	8-2
APPENDIX	A-1
Hierarchy of Remote Controller Key Operating Menus	A-2
(1) Hierarchy of Voltage, Current, Frequency and Other Factor Setting and Display Operating Menus	A-2
(2) Hierarchy of Memory Operating Menu	A-4
(3) Hierarchy of Special Function Operating Menu	A-6
INDEX	I-1

Chapter 1

GENERAL

Describes the features of the RC02-PCR-L and preparation for use.

Contents

1.1 For PCR-W ² Series User	1-2
1.2 Outline	1-2
1.3 Features	1-2
[Description] Regulation adjustment	1-3
1.4 About This Operation Manual and ROM Version	1-3

1.1 For PCR-W² Series User

The RC02-PCR-L is also suitable for use with the PCR-W² AC Power Supplies. PCR-W² AC Power Supply users can read "PCR-W" as "PCR-W²" in this manual for instructions on the use of such options.

To use the PCR-W² AC Power Supplies in the three-phase mode, read "Chapter 5 USING A PCR-W² IN THREE-PHASE MODE", which describes functions other than those for the single mode.

1.2 Outline

Use of the RC02-PCR-L with a PCR-W AC Power Supply significantly extends the power supply functions.

1.3 Features

Using the RC02-PCR-L allows the PCR-W AC Power Supplies to utilize the following enhanced functions in addition to the PCR-W Power Supply's standard functions.

■ Measurements of power-factor, VA, and peak holding current

Although the PCR-W AC Power Supplies have diverse measurement functions, these can be extended by connecting the Remote Controller. The additional functions include the measurement of power-factor, VA, and the peak holding current.

The peak holding current measurement function is useful for measuring a rush current.

■ Output ON/OFF phase setting

Output ON/OFF phase setting is available separately. This function is used when output ON/OFF phase setting is required.

■ AC + DC mode

This function allows the PCR-W AC Power Supply to output voltage waveforms in which AC voltage is superimposed on DC voltage. The function can be used in chemical experiments and for production equipment.

■ Expansion of the memory function

The PCR-W AC Power Supplies allow nine sets of voltage and frequency settings to be stored as standards in the memory, enabling the data to be read for output as necessary.

Connecting the Remote Controller enables the equipment to store up to 99 sets of voltage and frequency set values.

■ Regulation adjustment

With regulation adjustment, the output voltage is adjusted automatically to compensate for a voltage drop caused by the output current. This function is used for the same purpose as the

sensing function. The sensing function measures the sensing-point voltage in order to maintain a constant sensing-point voltage; with regulation adjustment, the voltage drop caused by the output current is calculated, and the output voltage is raised by an amount equivalent to the drop. The function ensures stabilized voltage at the load end without using sensing cables even if there is a substantial distance between the load and the PCR-W AC Power Supply.

[Description] Regulation adjustment

When regulation adjustment is performed, the PCR-W AC Power Supply's voltage stability accuracy, distortion factor, and response speed decrease below the normal capability. Therefore, this function may not be suitable for some applications. Check the load conditions and other factors before use.

1.4 About This Operation Manual and ROM Version

This manual applies to the RC02-PCR-L Remote Controller connected to a PCR-W AC Power Supply with ROM version 1.00 or higher.

- The RC02-PCR-L is a optional equipment of both the PCR-W Series and the PCR-L Series. This manual is described in case of the PCR-W Series with the RC02-PCR-L only.

When you inquire about the product, be prepared to provide us with the following information:

- PCR-W AC Power Supply model number
 - PCR-W AC Power Supply ROM version
 - PCR-W AC Power Supply serial number and revision number (indicated on the lower rear part of the equipment)
 - Remote Controller model number
 - Remote Controller serial number and revision number (indicated on the back of the Remote Controller)
- * Before using this Remote Controller, be sure to read the PCR-W AC Power Supply Operation Manual.

Chapter 2

INSTALLATION IN A PCR-W AC POWER SUPPLY

Describes how to install the remote controller card in a PCR-W AC power supply and how to connect and handle the remote controller.

Contents

2.1 Check at Unpacking	2-2
2.2 Remote Controller Handling Precautions	2-2
2.3 Installing the Remote Controller Card into a Slot	2-3
2.4 Connecting the Remote Controller Cable	2-4
2.5 Moving Precautions.....	2-5
2.6 How to Use the Magnet Sheet.....	2-5
2.7 Quick Reference Card	2-5

2.1 Check at Unpacking

This equipment was carefully tested and inspected both mechanically and electrically before shipment to ensure its normal operation.

The equipment should be checked upon receipt for damage that might have occurred during transportation. Also check if all accessories have been provided (see the following table). Should the equipment be damaged or any accessory missing, notify your Kikusui agent.

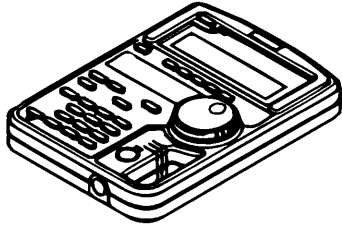

Remote controller box

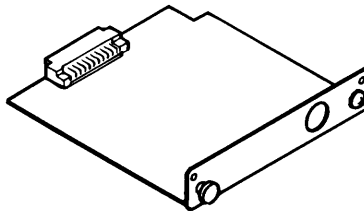

Remote controller card

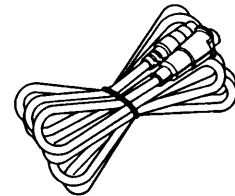

Remote controller cable

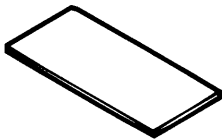

Magnet sheet

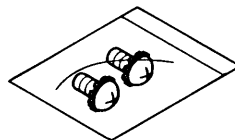

Mounting screws

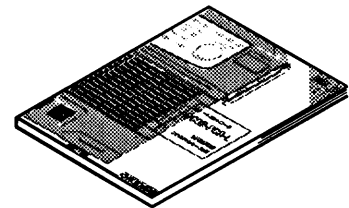

Operation Manual

Items	Q'ty	Check
Remote controller box	1	
Remote controller card	1	
Remote controller cable (2m)	1	
Magnet sheet	1	
Mounting screws (M3)	2	
Operation Manual	1	

2.2 Remote Controller Handling Precautions

The Remote Controller (RC02-PCR-L) consists of the remote controller card (interface card for the PCR-W AC Power Supply) installed in a PCR-W AC Power Supply, remote controller box used for operation, and remote controller cable that connects the controller card to the controller box. Observe the following handling precautions for these items.

■ Handling of remote controller card

Always take the following cautions when handling the remote controller card since its PCB is exposed.

CAUTION

- Never touch any of the electronics parts installed on the PCB.
- Never handle the card under conditions where static electricity might accumulate.
- After unpacking the Remote Controller carton, promptly install the remote controller card in a PCR-W AC Power Supply.
- When storing the remote controller card, always take measures to prevent static electricity, such as storing it in the bag used for the packing.
- Do not drop the card or subject it to other impact.
- Do not place the card where it could be exposed to water or other liquid.

■ Handling of remote controller box

CAUTION

- Do not drop the controller box or subject it to other impact.
- Do not place the controller box where it could be exposed to water or other liquid.
- Do not use or store the controller box in direct sunlight.
- Do not use or store the controller box in an area susceptible to rapid temperature changes.
- When the remote controller box is used with the provided magnet sheet, which attaches to the back of the controller box, never place the controller box near magnetic-susceptible items, such as floppy disks and credit cards.

2.3 Installing the Remote Controller Card into a PCR-W Slot

The remote controller card can be inserted into SLOT 1.

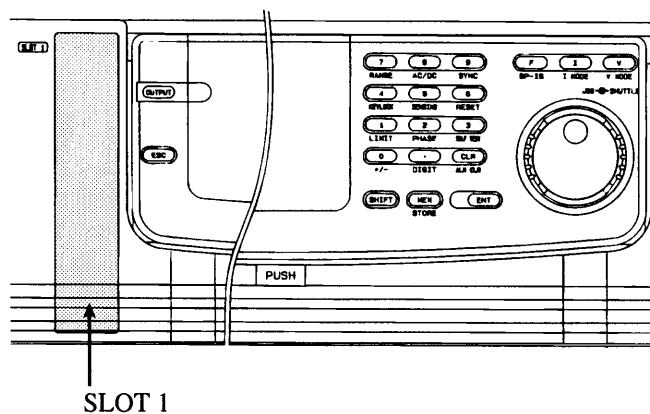

Upper front part of a PCR-W AC Power Supply

How to Install the Remote Controller Card into a Slot

CAUTION

- Before installing the controller card, always turn OFF the PCR-W AC Power Supply POWER switch.

- ▶ Step 1 Remove a slot cover.
- ▶ Step 2 Hold the panel part of the remote controller card.
- ▶ Step 3 Orient the controller card so that the parts-mounted side of the PCB is at the right, and place the PCB into the slot grooves.
- ▶ Step 4 Carefully insert the controller card into the slot so that the PCB does not come out of the grooves.
- ▶ Step 5 Insert the card all the way, then fix the card to the PCR-W AC Power Supply using the screws provided. This completes installation of the remote controller card.

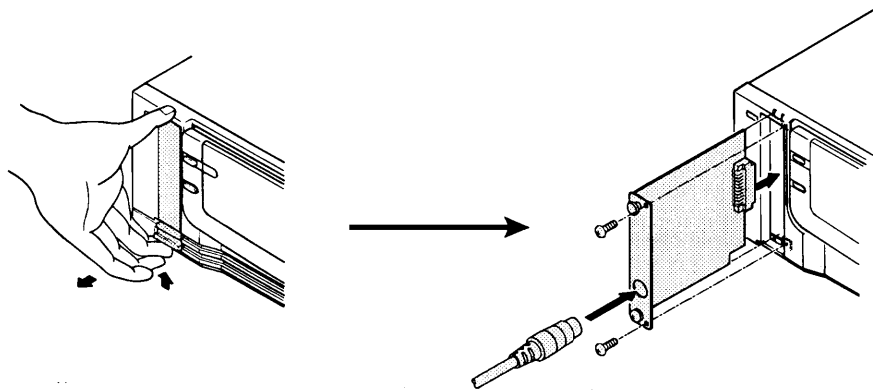

2.4 Connecting the Remote Controller Cable

CAUTION

- Before connecting the controller cable, always turn OFF the PCR-W AC Power Supply POWER switch.

- ▶ Step 1 Connect the controller cable connector with a protection cover to one of the two connectors in the remote controller box. Exercise care that the orientation of the connector is correct. Insert the protection cover, cover the connector and turn the cover clockwise to fix it securely.

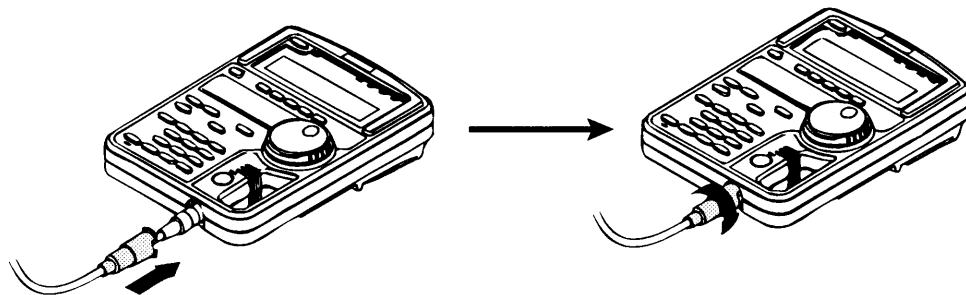

- ▶ Step 2 Connect the other connector of the controller cable to the remote controller card connector. Exercise care that the orientation of the connector is correct.

2.5 Moving Precautions

CAUTION

- Moving a PCR-W AC Power Supply with this device connected may place unreasonable stress on the remote controller cable or cause the remote controller box to fall. Before moving the PCR-W AC Power Supply, always disconnect the controller cable.
- When the magnet sheet is used, do not move a PCR-W AC Power Supply with the remote controller box attached to the side of the equipment. Vibration during movement may cause the remote controller box to fall.
- When moving the equipment, follow the instructions given in the PCR-W AC Power Supply Operation Manual.

2.6 How to Use the Magnet Sheet

The Remote Controller has a magnet sheet that can be attached to the back of the remote controller box. This allows the remote controller box to be placed on the side panel of the PCR-W AC Power Supply or other steel surface.

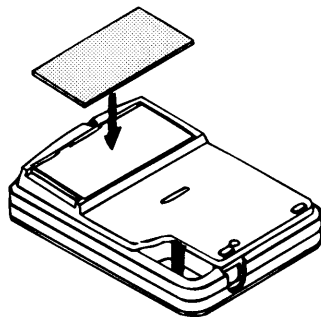

CAUTION

- When the provided magnet sheet is on the back of the remote controller box, never place the controller box near magnetic-susceptible items, such as floppy disks and credit cards.

2.7 Quick Reference Card

The remote controller box has a quick reference card that briefly describes keys and simulation waveforms. This card is useful when using the memory function. (The PCR-W and PCR-W² Series do not have a simulation function.)

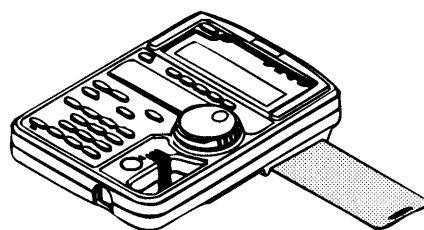

Chapter 3

OPERATION CHECK

Describes the operation check that must be conducted before operating the RC02-PCR-L.

Contents

3.1 Checking the Initial Setup Status	3-2
[Description] Home Position	3-2
[Description] ENTER Wait	3-3
[Description] LCD (Liquid Crystal Display) Contrast Adjustment	3-3
3.2 Operation Check	3-3
[Description] Back-up data has been lost	3-4

After connecting the Remote Controller by the steps described in Chapter 2, check the Initial Setup Status and make an operation check. Always make an operation check as described in this chapter, if you have installed a new Remote Controller or changed its location, if the operator changes, or if the Remote Controller has not been used for a long time.

3.1 Checking the Initial Setup Status

The condition in which a PCR-W AC Power Supply and this device are simultaneously purchased and power is fed for the first time (factory shipment status) is called Initial Setup Status. The following figure shows the remote control box LCD display under this condition.

50.00Hz	0.00A	0.2V
FRQ	I _{rms}	V _{rms}

The main setting in the Initial Setup Status are as follows:

- OUTPUT OFF
- RANGE 100V
- AC/DC AC
- Frequency 50.00Hz
- Voltage 0.0V
- Voltage display mode RMS
- Current display mode RMS

If the Remote Controller is not in the Initial Setup Status, use the reset function to activate the Initial Setup Status. Reset can be performed either on the PCR-W AC Power Supply or via the Remote Controller. To perform a reset on the PCR-W AC Power Supply, see instructions in the PCR-W AC Power Supply Operation Manual.

- Note that performing a reset cancels all settings made thus far and activates the Initial Setup Status.

Resetting Procedure using the Remote Controller

Check that the PCR-W AC Power Supply is in the key-lock mode, then take the following steps.

- ▶ Step 1 Call the Home Position. (See the Home Position description given below.)
- ▶ Step 2 Press SHIFT + 6 (RESET).
- ▶ Step 3 Verify that the ENTER LED blinks, activating ENTER wait status.
- ▶ Step 4 Press SHIFT + ENTER. This executes a reset.

The above procedure also cancels the PCR-W Power Supply key lock mode. To use the Remote Controller, set the PCR-W AC Power Supply to the key-lock mode again.

[Description] Home Position

The status obtained immediately after turning the POWER switch ON is called the Home Position. To return to the Home Position from another status, press ESC once or twice (regardless of OUTPUT ON/OFF status).

[Description] ENTER Wait

This is the condition in which ENTER has not yet been pressed to initiate the operations performed thus far. In this condition, the ENTER LED on the Remote Controller blinks. To cancel a operation before pressing ENTER, press ESC. ENTER Wait for this device has the same meaning as the ENT Wait of the PCR-W AC Power Supplies.

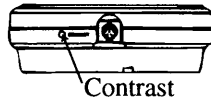
[Description] LCD (Liquid Crystal Display) Contrast Adjustment

To adjust the contrast of the Remote Controller LCD unit, use a small screwdriver to turn the part shown in the figure. Adjust LCD contrast to match lighting conditions at the operating location to obtain an easy-to-see display.

3.2 Operation Check

CAUTION

- Remote Controller operation must be checked after the operation check of the PCR-W AC Power Supply has been completed.

Operation Check Procedure

The following describes how to make an operation check from the Initial Setup Status.

- ▶ Step 1 Turn the PCR-W AC Power Supply POWER switch ON.
- ▶ Step 2 The remote controller box LCD displays the following Initial Setup Status for a few seconds (the example shown is for PCR2000W with ROM version 1.00).

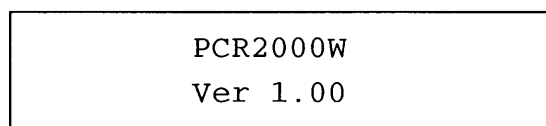

If a different display appears, see the description on the next page.

- ▶ Step 3 After a few seconds, the Home Position appears.

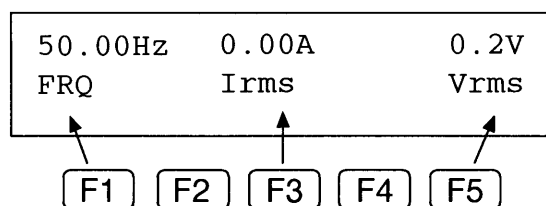

If the PCR-W AC Power Supply is not in the key-lock mode, set the equipment to the key-lock mode.

- ▶ Step 4 Press F5 (Vrms) to enter the voltage setting mode. This changes the F5 Vrms indication to Vset.

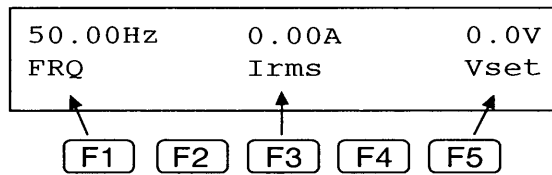

- ▶ Step 5 Turn JOG or SHUTTLE to check that the voltage changes on the display.
- ▶ Step 6 This completes the operation check.

This operation check does not check all functions. However, if the operation check has been complete, the main functions operate correctly.

[Description] Back-up data has been lost

If the following display or other messages appear, wait for about ten seconds, then the display should change to the Initial Setup Status. In this condition, the PCR-W AC Power Supply back-up data has been lost for some reasons. Re-check the steps described in sections 2.3 to 2.4. If this still does not remedy the condition, notify your Kikusui agent.

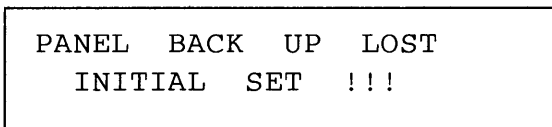

Chapter 4

OPERATION METHOD

Describes the operation and functions of the RC02-PCR-L.

Contents

4.1 Basic Operation of the Remote Controller	4-2
4.2 Functions in Common with the PCR-W	
AC Power Supply	4-3
4.2.1 Functions Whose Key Operation is the Same as That of the PCR-W AC Power Supply ...	4-3
4.2.2 Functions Whose Key Operation Differs from That of the PCR-W AC Power Supply	4-3
4.3 Functions Extended by Using the Remote Controller	4-4
4.3.1 AC + DC Mode	4-4
4.3.2 Memory Function	4-6
4.3.3 Power, Power-Factor, and Volt-ampere Measurement Mode	4-8
4.3.4 Peak Holding Current Measurement Mode [Description] Peak Value and Peak Holding Value Measurements	4-9
4.4 Functions Added by Using the Remote Controller	4-10
4.4.1 Output ON/OFF Phase Setting	4-10
[Description] Removing the RC02-PCR-L after Output ON/OFF phase has been set	4-11
4.4.2 Regulation Adjustment	4-11

4.1 Basic Operation of the Remote Controller

Remote controller operation is designed to be as much as possible the same as that of the PCR-W AC Power Supply control panel. However, part of the operation and operation of new functions provided by the Remote Controller differ from that of the PCR-W Power Supply control panel.

The basic operating method of the Remote Controller is as follows:

- Confirm that the PCR-W AC Power Supply is in the key-lock mode.

▶ **Operation 1** To enter main function setting or execution status, press the relevant key (MEM or MODE). Note that these keys are accepted only in the Home Position. For information on how to use JOG and SHUTTLE, see 6.7, How to Use JOG and SHUTTLE, in the PCR-W AC Power Supply Operation Manual.

▶ **Operation 2** After entering each function setting or execution status, press the F1 to F5 function keys (located right below the items displayed at the lower part of the display). The function keys correspond to the displayed items. For example, in the following display (memory edit display), F1 corresponds to "ADRS", F3 to "FRQ", and F5 to "Vrms".

Note that there are slight deviations between the displayed letters and key positions.

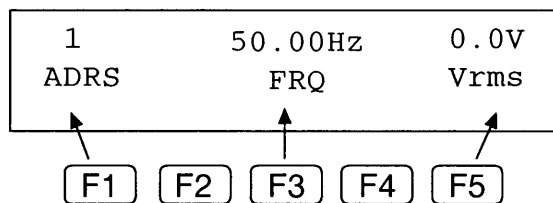

In this operation manual, pressing of one of the F1 to F5 function keys is indicated such as F1 (Vrms). The item in parentheses corresponds to the indication at the lower part of the display. Also, use items separated by "/" in parentheses, such as (Vrms/Vpk/Vset/Vave), means that one of such items will be displayed depending on the status at the time.

▶ **Operation 3** If there are several operation displays, the MENU LED lights. Press MENU to access the next display.

For three or more operation displays, press SHIFT + MENU to return to the previous display.

▶ **Operation 4** To exit the current status, press ESC.

▶ **Operation 5** Blinking of the ENTER LED during operation means that the ENTER wait status is activated.

▶ **Operation 6** In the ENTER wait status, operation input thus far is not initiated until ENTER is pressed. Pressing ESC cancels the ENTER Wait status.

4.2 Functions in Common with the PCR-W AC Power Supply

This section discusses the functions common to the Remote Controller and the PCR-W AC Power Supply control panel. The functions are separated into those that can be accomplished in the same way as on the PCR-W AC Power Supply and those requiring different key operation.

4.2.1 Functions Whose Key Operation is the Same as That of the PCR-W AC Power Supply

The following functions are the same key operation as that of the PCR-W AC Power Supply control panel. For details about operation, refer to the PCR-W AC Power Supply Operation Manual.

Functions whose key operation is the same as that of the PCR-W AC Power Supply

Functions	Key operation
OUTPUT ON/OFF	OUTPUT
Self-test function	SHIFT + 3 (SELF TEST)
Key-lock function	SHIFT + 4 (KEYLOCK)
Sensing function	SHIFT + 5 (SENSING)
Reset function	SHIFT + 6 (RESET)
Output voltage range change	SHIFT + 7 (RANGE)

4.2.2 Functions Whose Key Operation Differs from That of the PCR-W AC Power Supply

Some functions available on the PCR-W AC Power Supply control panel require slightly different key operation on the Remote Controller because of the device's key arrangement.

Functions whose key operation differs from that of the PCR-W AC Power Supply

Functions	PCR-W AC Power Supply	Remote Controller
Voltage setting function	V	F5 (Vrms/Vpk/Vset/Vave)
Frequency setting function	F	F1 (FRQ)
Limit value setting function	V	F5 (Vmax/Vmin)
	F	F1 (Fmax / Fmin)
	I	F3 (Imax)
Voltage display mode change	SHIFT + V	SHIFT + F5 (Vrms/Vpk/Vset/Vave)
Current display mode change	SHIFT + I	SHIFT + F3 (Irms/Ip/Iph/WATT/Iave)

The meaning of the abbreviations Vrms, Vpk, Vset, etc, are as follows:

Vrms = rms voltage	Fmax = maximum frequency
Vpk = peak voltage	Fmin = minimum frequency
Vset = set voltage	Imax = maximum current
Vave = average voltage	Irms = rms current
FRQ = frequency	Ip = peak current
Vmax = maximum voltage	Iph = peak holding current
Vmin = minimum voltage	WATT = power
	Iave = average current

For an explanation of set values, rms, peak values, and average values, see the Description "Voltage Display Mode" in 6.8.1, Switching the Voltage Display Mode, of the PCR-W AC Power Supply Operation Manual.

Voltage setting function

To enter the voltage setting mode on the Remote Controller, press F5 (Vrms/Vpk/Vset/Vave) in the Home Position. (On the PCR-W AC Power Supply, press V.)

Frequency setting function

To enter the frequency setting mode on the Remote Controller, press F1 (FRQ) in the Home Position. (On the PCR-W AC Power Supply, press F.)

Limit value setting function

To enter the voltage, frequency, or current limit setting mode on the Remote Controller, press SHIFT + 1 (LIMIT) to enter the limit value display mode, then press F5 (Vmax/Vmin), F1 (Fmax/Fmin), or F3 (Imax). (On the PCR-W AC Power Supply, press SHIFT + 1 (LIMIT) to enter the limit value display mode, then press V, F or I.) This function is valid only in AC or DC mode.

Voltage display mode change

To switch the voltage display mode on the Remote Controller, press SHIFT + F5 (Vrms/Vpk/Vset/Vave). (On the PCR-W AC Power Supply, press SHIFT + V.)

Current display mode change

To switch the current display mode on the Remote Controller, press SHIFT + F3 (Irms/Ip/Iph/WATT/Iave). (On the PCR-W AC Power Supply, press SHIFT + I.) The PCR-W AC Power Supply control panel has no "Iph" display mode. This function is added by the Remote Controller. For details, see 4.3.4, Peak Holding Current Measurement Mode.

4.3 Functions Extended by Using the Remote Controller

The Remote Controller extends some of the PCR-W AC Power Supply functions. This section describes the extended functions and how to use them.

4.3.1 AC + DC Mode

The PCR-W AC Power Supplies allow two output voltage modes, AC and DC. Use of the Remote Controller allows an additional output voltage mode, AC + DC mode. The AC + DC mode is a function that superimposes DC voltage on AC voltage or vice versa.

Output Voltage Mode Change Procedure

The output voltage mode can be changed only when OUTPUT is OFF in the Home Position.

- Confirm that the PCR-W AC Power Supply is in the key-lock mode.

▶ Step 1 Press OUTPUT to turn output OFF (OUTPUT LED is OFF on the Remote Controller).

- ▶ Step 2 Press ESC to call the Home Position.
- ▶ Step 3 Press SHIFT + 8 (AC/DC) to activate the ENTER Wait status. Then press ENTER to establish the output voltage mode. The control panel display in the ENTER wait status changes as follows depending on the mode at the time.

Current Mode	PCR-W Power Supply	Remote Controller
AC	AC - +DC -	AC - DC -
DC	- AC - +DC -	- AC - DC -
AC + DC	- AC - +DC	- AC - DC

- · - · - indicates blinking.

Output Voltage Mode Selection

The AC, DC, and AC + DC output voltage modes are selected in the order of

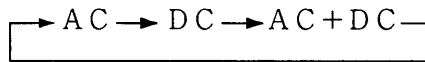

whenever SHIFT + 8 (AC/DC) and then ENTER are pressed.

In the AC + DC mode, the AC + DC voltage peak value can be set in the DC voltage setting range.

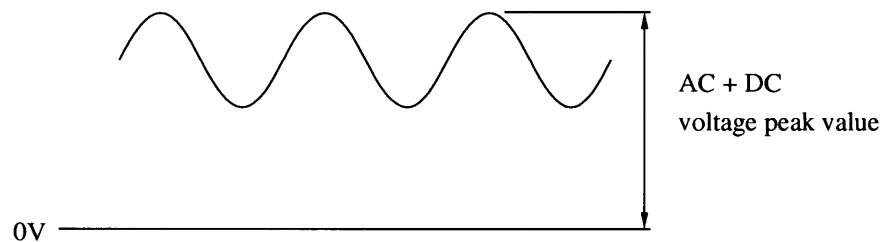

- In the AC + DC mode, the voltage and frequency limit values respectively set in the AC or DC modes are valid. The AC + DC mode does not allow current limit change. This limit is fixed to the maximum value in the DC mode.
- In the AC + DC mode, the PCR-W AC Power Supply key-lock mode cannot be canceled.

Output Voltage Setting Procedure

- ▶ Step 1 Press ESC to call the Home Position.
- ▶ Step 2 Press F5 to activate the voltage setting mode.
- ▶ Step 3 Press F5 again. This causes the power supply to enter the AC/DC voltage setting switching mode. Then, "AC" blinks in the Remote Controller's MODE display area. Set AC output voltage using the numeric keys or JOG/SHUTTLE. (For setting using the numeric keys, press ENTER after setting an AC output voltage value to fix the value.)

- ▶ Step 4 Press F5 again. This causes "DC" to blink in the Remote Controller's MODE display area. Then, set DC voltage using the numeric keys or JOG/SHUTTLE. (For setting using the numeric keys, press ENTER after setting a DC voltage value to fix the value.)
- ▶ Step 5 When F5 is pressed, the AC and DC voltage setting modes are toggled. Change the mode as desired.

4.3.2 Memory Function

The PCR-W AC Power Supplies have the memory function that stores nine sets of voltage and frequency settings in memory addresses up to 9 and allows them to be read for output whenever necessary. Connecting the Remote Controller to a PCR-W AC Power Supply allows the number of set values stored in the memory (memory addresses) to be extended to 99. The Remote Controller also offers memory operation in the AC + DC mode, allowing simultaneous output of AC and DC voltages stored in the same memory address. For memory addresses 1 to 9, setting is common to both the PCR-W AC Power Supply and the Remote Controller.

The procedure to store datas in the memory is as follow:

Memory Setting Procedure

Memory setting is available only in the Home Position.

- Confirm that the PCR-W AC Power Supply is in the key-lock mode.

- ▶ Step 1 Press ESC to call the Home Position.
- ▶ Step 2 Press SHIFT + MEN (M-EDIT) to enter the memory edit mode. This causes the LCD to display the following:

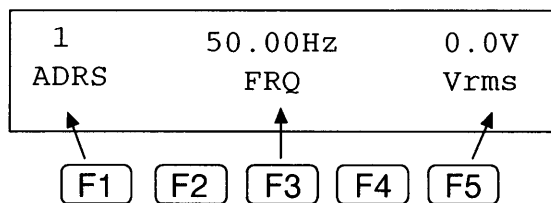

- ▶ Step 3 Using the F1, F3, and F5 function keys and MENU, select the desired item. Selectable items are as follows. To select an item, follow steps 4 onward.

Key	Setting items	Mode available
F1 (ADRS)	Memory address (step 4)	
F3 (FRQ)	Frequency (step 4)	AC or AC + DC mode
F5 (Vrms)	AC voltage (step 4)	AC or AC + DC mode
MENU, then F1 (ADRS)	Memory address	
MENU, then F5 (Vdc)	DC voltage (step 5)	DC or AC + DC mode

► Step 4 The cursor blinks at "1" of ADRS. Enter the desired address and press ENTER to fix it.

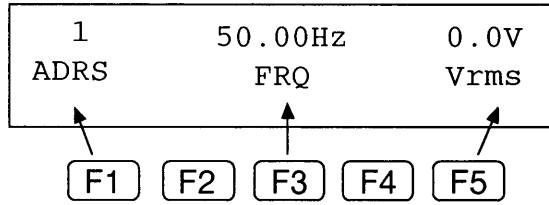

Next, press F3 to set frequency or F5 to set AC voltage. The cursor moves to "FRQ" or "Vrms". Set the value you wish to store in the memory using the numeric keys or JOG/SHUTTLE.

► Step 5 To set DC voltage, press MENU to call the following display, then set DC voltage (F5).

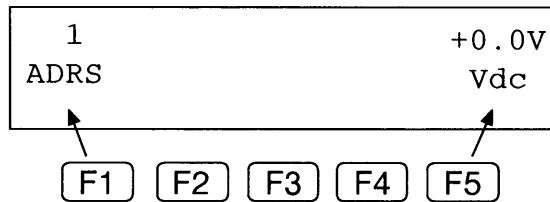

► Step 6 Press ESC to quit the memory edit mode.

CAUTION

- Note that when voltage data is read from the memory in the AC + DC mode for output, output voltage changes as follows:
An AC voltage set value (Vrms) and DC voltage set value (Vdc) are independently stored in the memory. When they are read, the AC voltage value (Vrms) is output slightly faster (approximately 30 μs) than the DC voltage value (Vdc). Therefore, output voltage changes as follows:

Example ADRS 1: Vrms = 0V, Vdc = +100V
 ADRS 2: Vrms = 100V, Vdc = 0V
 ADRS 3: Vrms = 0V, Vdc = +100V

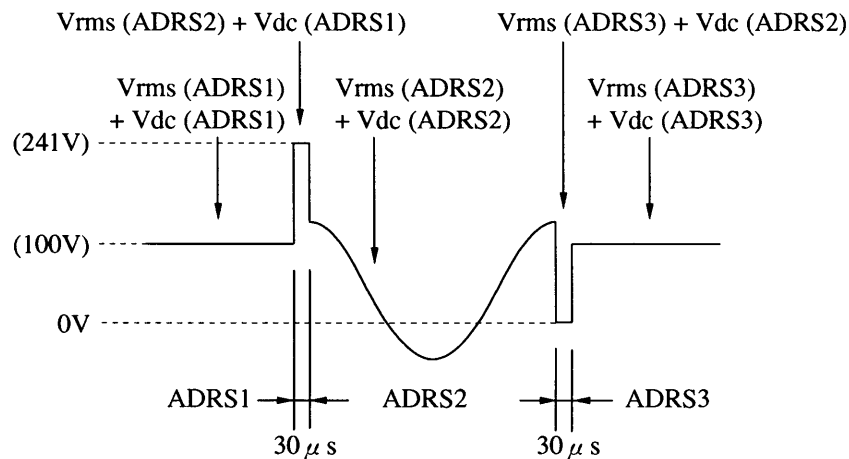

In the actual case, the duration of 30 μs shown in the above figure is very short in comparison with each ADRS time. Output voltage changes like pulse.

Memory Read Procedure

Set the mode (AC, DC, or AC + DC) in the same condition as that of setting data in the memory.

To read data set in each address ("ADRS"), take the following steps.

▶ Step 1 Press ESC to call the Home Position.

▶ Step 2 Press MEM to display the memory content. This causes the following display to appear.

1	50.00Hz	0.0V	(First display)
ADRS	FRQ	Vrms	(Example of Initial Setup Status)

▶ Step 3 Using the numeric keys or JOG/SHUTTLE, set the address and press ENTER (ENTER should also be pressed if using JOG/SHUTTLE). This causes the frequency and AC voltage set in the relevant address to appear.

2	100.0Hz	100V	(First display)
ADRS	FRQ	Vrms	(Example of the display showing that FRQ = 100 Hz and Vrms = 100 V are set in ADRS2)

▶ Step 4 To display DC voltage set in the same address, press MENU. This causes the following display to appear.

2	+0.0V	(Second display)
ADRS	Vdc	(Example of the display showing that DC voltage +0 V is set in ADRS2)

Set an address by using the numeric keys or JOG/SHUTTLE, and pressing ENTER to fix the address in this way, allows the data set in such address to appear. Use MENU to select the first or second display.

▶ Step 5 Press ESC to quit the memory content display.

4.3.3 Power, Power-Factor, and Volt-ampere Measurement Mode

The PCR-W AC Power Supplies have a power display function. However, using the Remote Controller allows simultaneous display of power, power-factor, and volt-ampere (VA).

Procedure for Switching to Power, Power-Factor, and Volt-ampere Display

- Confirm that the PCR-W AC Power Supply is in the key-lock mode.

▶ Step 1 Press ESC to call the Home Position.

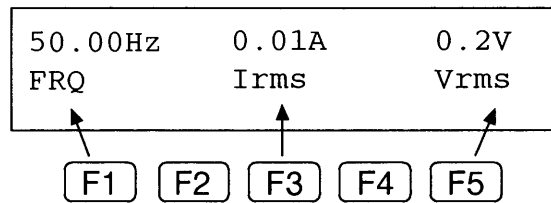

- Step 2 Press MENU. This causes the power (WATT), volt-ampere (V.A) and power factor (P.F) display to appear.

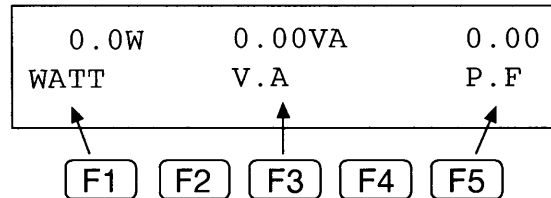

- Press MENU again, or press ESC to call the Home Position.

4.3.4 Peak Holding Current Measurement Mode

The PCR-W AC Power Supplies have the peak current display function. However, using the Remote Controller allows peak holding current display in addition to peak current display. The difference between peak value and peak holding value measurements is as follows:

[Description] Peak Value and Peak Holding Value Measurements

Peak value measurement

In peak value measurement, the peak value is cleared for every measurement cycle. The Remote Controller's peak value measurement measures the current peak using the analog peak holding circuit and obtains the maximum absolute value of that data. Therefore, peak current display shows an absolute value (no positive or negative symbol). A peak value can be measured in the AC, DC, or AC + DC mode.

Peak holding value measurement

Peak holding value measurement holds the maximum peak value until a peak clear signal is received. One of the following signal applies to generate a peak clear operation. Peak holding current measurement is useful in measuring rush current of a load occurring at power ON.

- Peak clear operation (press F4 (clr)) using the Remote Controller.
- Peak clear command via the GPIB interface or RS-232C interface (see the IB11/RS11 Operation Manual PCR-W Series Edition).

The Remote Controller's peak holding value measurement measures peak current using the analog peak holding circuit. It obtains the maximum absolute value of that data. Therefore, peak current display shows an absolute value, which has no positive or negative symbol. The peak holding value can be measured in the AC, DC, or AC + DC mode.

Peak Holding Current Measurement Mode Operating Procedure

Press SHIFT + F3 in the same way as current measurement mode change. This causes the indication to change in the following order in the AC mode.

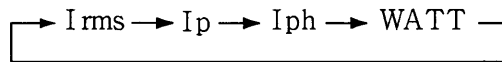

In the DC or AC + DC mode, the indication changes as follows:

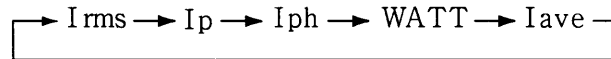

Where "Iph" is peak current value display and "Iph" is peak holding current value display.

Peak Clear Procedure

To execute a peak clear in the peak holding current measurement, press F4 (clr).

4.4 Functions Added by Using the Remote Controller

Some functions are available only by using the Remote Controller. This section describes how to use such functions.

4.4.1 Output ON/OFF Phase Setting

Output ON/OFF phase setting is available separately. In the Initial Setup Status, no output ON/OFF phase is set in the Remote Controller (phase is random). This function is used if output ON/OFF phase setting is required for a case such as rush current simulation.

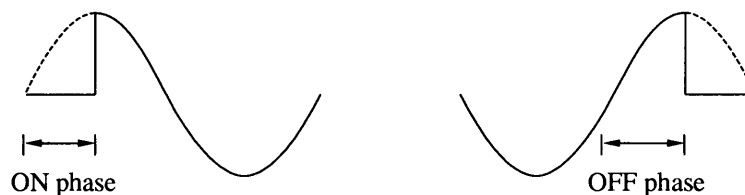

Output ON/OFF Phase Setting Procedure

- Output impedance setting is available only in the AC mode.
- Confirm that the PCR-W AC Power Supply is in the key-lock mode.

- ▶ Step 1 Press ESC to call the Home Position.
- ▶ Step 2 Press MODE. This causes the following display to appear.

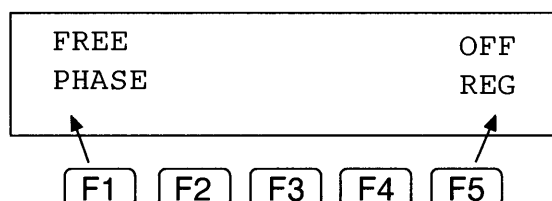

- ▶ Step 3 Press F1 (PHASE) to select the output ON/OFF phase setting mode. The following display appears.

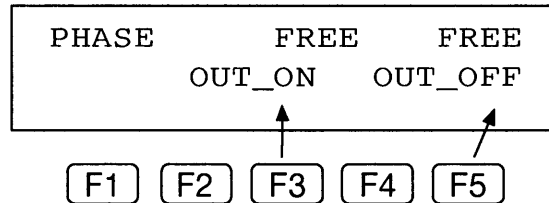

- ▶ Step 4 Press F3 (OUT_ON) or F5 (OUT_OFF) to select ON or OFF phase. If F3 (OUT_ON) is pressed, the following display appears.

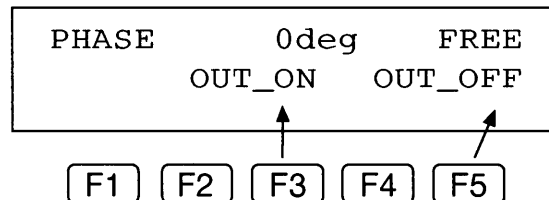

If either F3 (OUT_ON) or F5 (OUT_OFF) is pressed, the "FREE" (no setting) and "_deg" (setting) indications appears alternately.

- ▶ Step 5 For selection of "_deg" (setting), set phase using the numeric keys or JOG/SHUTTLE (for setting using the numeric keys, press ENTER to fix the selection) When the output ON/OFF phase setting function is operating, "4" lights in the PCR-W AC Power Supply S-MODE area.
- ▶ Step 6 Press ESC to exit the output ON/OFF phase setting mode.

[Description] Removing the RC02-PCR-L after Output ON/OFF phase has been set

The set content is backed up inside the PCR-W AC Power Supply. Therefore, once a setting is made using the Remote Controller, the power supply can operate in the same condition continuously even if the device is disconnected, as long as the setting conditions remain the same.

To cancel the output ON/OFF phase setting by the PCR-W AC Power Supply only, perform resetting the PCR-W. However, since other settings are also canceled, the PCR-W is set in Initial Setup Status.

4.4.2 Regulation Adjustment

With regulation adjustment, the output voltage is adjusted automatically in accordance with output current. This function is used for the same purpose as the sensing function. The sensing function measures the sensing-point voltage in order to maintain a constant sensing-point voltage; with regulation adjustment, the voltage drop caused by the output current is calculated in order to raise the output voltage by an amount equivalent to the drop.

This function is used to stabilize voltage at the load end without using sensing cables if there is a considerable distance between the load and the PCR-W AC Power Supply.

- When regulation adjustment is performed, the PCR-W Power Supply's voltage stability accuracy, distortion factor, and response time decrease below the normal capability. Therefore, this function may not be suitable for some applications. Check the load conditions and other requirements carefully before use.

Regulation Adjustment Setting Procedure

- Connect a load to the PCR-W AC Power Supply in accordance with Chapter 5 of the PCR-W AC Power Supply Operation Manual. Set OUTPUT to ON, and set output voltage to the level required at the load end. At the load end, the voltage falls below the voltage level at the PCR-W Power Supply because of a voltage drop caused by the load cable. Prepare a voltmeter to check if the voltage at the load end has the required level. To perform regulation adjustment, the output current must be at least 1/10 of the PCR-W Power Supply rated current
- The voltage that can be corrected using the regulation adjustment function is up to +10% of the PCR-W Power Supply output voltage.

Confirm that the PCR-W AC Power Supply is in the key-lock mode.

▶ Step 1 Press ESC to call the Home Position.

▶ Step 2 Press MODE. This causes the following display to appear.

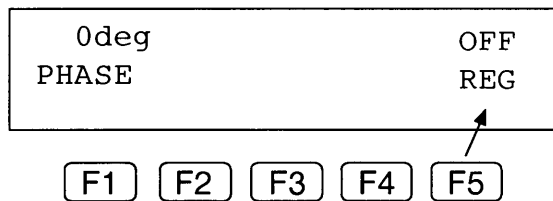

▶ Step 3 Press F5 (pressing this key toggles between ON and OFF) to set regulation adjustment to ON.

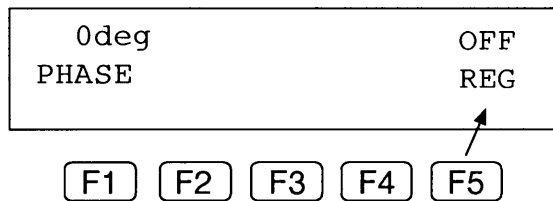

▶ Step 4 When this function is set ON, flow current to the load. By observing the voltmeter connected to the load end, adjust the voltage using JOG/SHUTTLE so that the voltage at the load end attains the required voltage value.

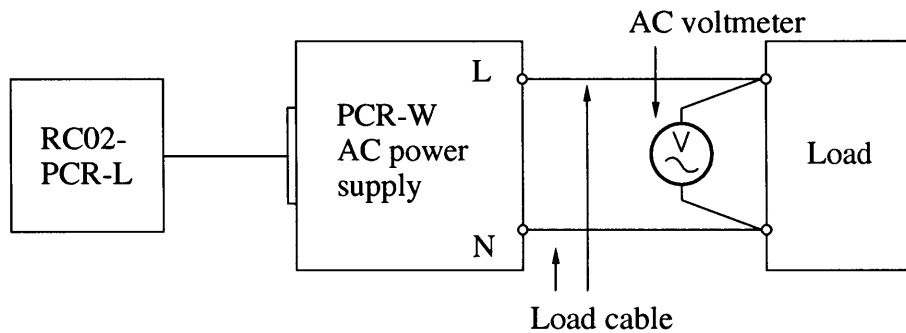

▶ Step 5 Press ESC to exit the regulation adjustment setting mode.

Chapter 5

USING A PCR-W² IN THREE PHASE MODE

Describes the functions available in the three-phase mode of the PCR-W² AC Power Supplies that are different from those available in the single-phase mode.

Contents

5.1 Limited Functions	5-2
5.2 Switching between Phase Voltage Display and Line Voltage Display	5-2
5.3 Output Voltage Setting	5-3
5.4 Display of V-/W-Phase Current, V-/W-Phase Voltage, or V-to-W/W-to-U Line Voltage	5-4
5.5 Selecting the Current/Power Display Mode	5-4
5.6 Setting U-to-V or U-to-W Phase Difference	5-5

This chapter only describes the use of the PCR-W² AC Power Supplies in the three-phase mode. If using the PCR-W AC Power Supplies, skip this chapter.

If the PCR-W² AC Power Supplies and the RC02-PCR-L are used in combination in the three-phase mode, the functions described below are different from those available in the single-phase mode.

5.1 Limited Functions

The following mode cannot be used:

- DC and AC + DC modes
- Regulation adjustment

5.2 Switching between Phase Voltage Display and Line Voltage Display

The PCR-W² Series AC Power Supplies have phase voltage and line voltage display modes.

Selecting the Voltage Display

- ▶ Step 1 Press ESC to call the home position.
- ▶ Step 2 Press SHIFT + 2 (PHASE) to select either phase voltage display mode or line voltage display mode for the output phase you wish to display. Each time SHIFT + 2 (PHASE) is pressed, the voltage display mode changes as follows:

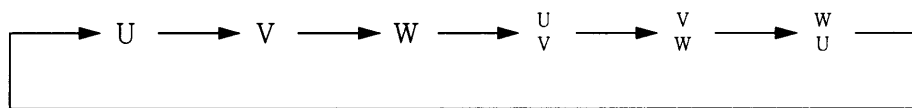

- Phase voltage display mode

When the letter U, V, or W is displayed at the left of the voltage display, the phase voltage display mode is selected.

50.00Hz	0.00AU	0.2V
FRQ	I _{rms}	V _{rms}

- Line voltage display mode

When the symbol $\frac{U}{V}$, $\frac{V}{W}$, or $\frac{W}{U}$ is displayed at the left of the voltage display, the line voltage display mode is selected.

50.00Hz	0.00A $\frac{U}{V}$	0.2V
FRQ	I _{rms}	V _{rms}

- In line voltage display mode, the condition of the current display area is as follows.

Voltage display mode	Display	Current display
U-to-V line voltage	U V	U-phase current
V-to-W line voltage	V W	V-phase current
W-to-U line voltage	W U	W-phase current

5.3 Output Voltage Setting

The PCR-W² Series AC Power Supplies have phase voltage and line voltage setting modes.

- ▶ Step 1 Press ESC to call the home position.
- ▶ Step 2 Press SHIFT + 2 (PHASE) to select either phase voltage display mode or line voltage display mode for the output phase you wish to display.
- ▶ Step 3 Press F5 to select the voltage setting mode (Vset).

- Phase voltage setting mode

Sets the phase voltage of the letter displayed at the left of the voltage display.

50.00Hz	0.00AU	0.0V
FRQ	I _{rms}	Vset

- Three-phase voltage setting mode

Select the U-phase voltage setting mode and press SHIFT + 2 (PHASE). This selects the three-phase voltage setting mode.

The λ symbol appears at the left of the voltage display.

50.00Hz	0.00A λ	0.0V
FRQ	I _{rms}	Vset

- Line voltage setting mode

Δ symbol appears at the left of the voltage display when the line voltage setting mode has been selected.

50.00Hz	0.00A Δ	0.0V
FRQ	I _{rms}	Vset

- While in line voltage setting mode, the U-to-V phase difference must be 120 degrees and U-to-W phase difference must be 240 degrees for selection to be made. Also, the voltage setting for each phase must be identical.
- In line voltage setting mode, the U-to-V phase difference and U-to-W phase difference cannot be changed.
- Measurement of output voltage is not available in line voltage display mode.

5.4 Display of V-/W-Phase Current, V-/W-Phase Voltage, or V-to-W/W-to-U Line Voltage

Press ESC to call the home position.

Whenever MENU is pressed, the display changes as follows:

- In phase voltage display mode

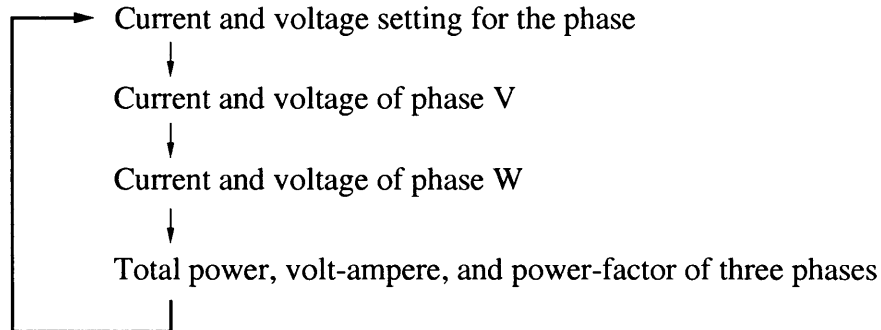

- In line voltage display mode

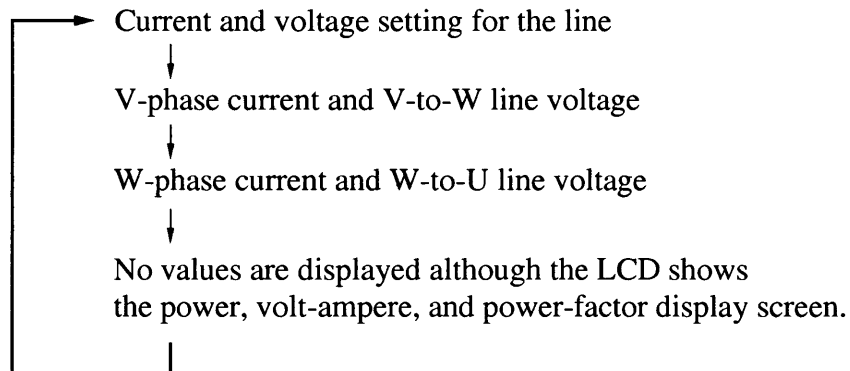

5.5 Selecting the Current/Power Display Mode

- Whenever SHIFT + F3 is pressed from the home position, the current/power display mode changes as follows:

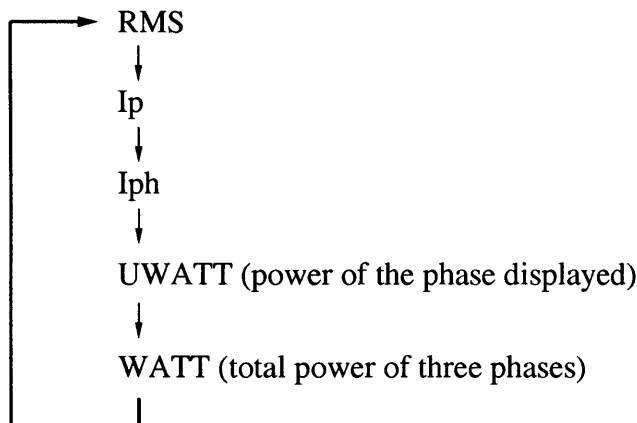

- The phase power/total three-phase power display mode is selected from line voltage display mode, but no values are displayed on the LCD.

5.6 Setting U-to-V or U-to-W Phase Difference

- ▶ Step 1 Press ESC to call the home position.
- ▶ Step 2 Press MODE. This causes the following display to appear.

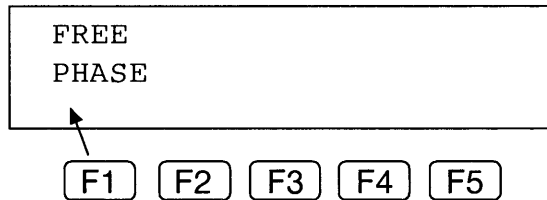

- ▶ Step 3 Press F1 (PHASE) to select the phase setting mode. This causes the following display to appear.

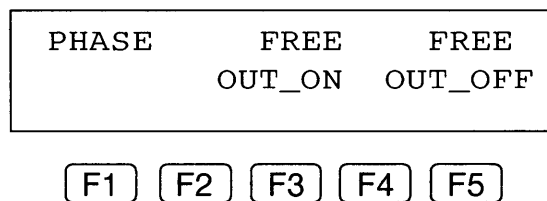

- ▶ Step 4 Press MENU to select the U-to-V/U-to-W phase difference setting mode. This causes the following display to appear.

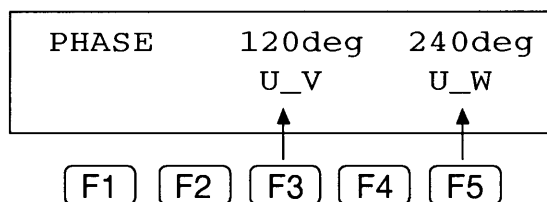

- ▶ Step 5 Press F3 (U-V) or F5 (U-W) to select the U-to-V or U-to-W phase difference.
- ▶ Step 6 Set the phase difference.
- ▶ Step 7 Press ESC to exit the phase difference setting mode.

Chapter 6

PART NAMES AND OPERATIONS

Indicates the names of the parts of the RC02-PCR-L and describes these functions of these parts.

Contents

6.1 Remote Controller Card	6-2
6.2 Remote Controller Box	6-2

6.1 Remote Controller Card

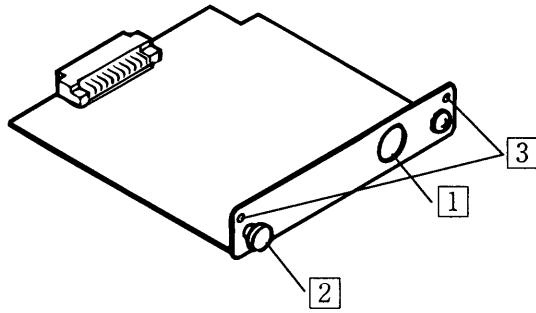

- 1** 8-contacts mini-plug connector
Used for connecting the remote controller cable.
- 2** Pull-out knob
Used to extract the remote controller card from a slot in the PCR-W AC Power Supply.
- 3** Screw holes
Holes for screws when installing the remote controller card.

6.2 Remote Controller Box

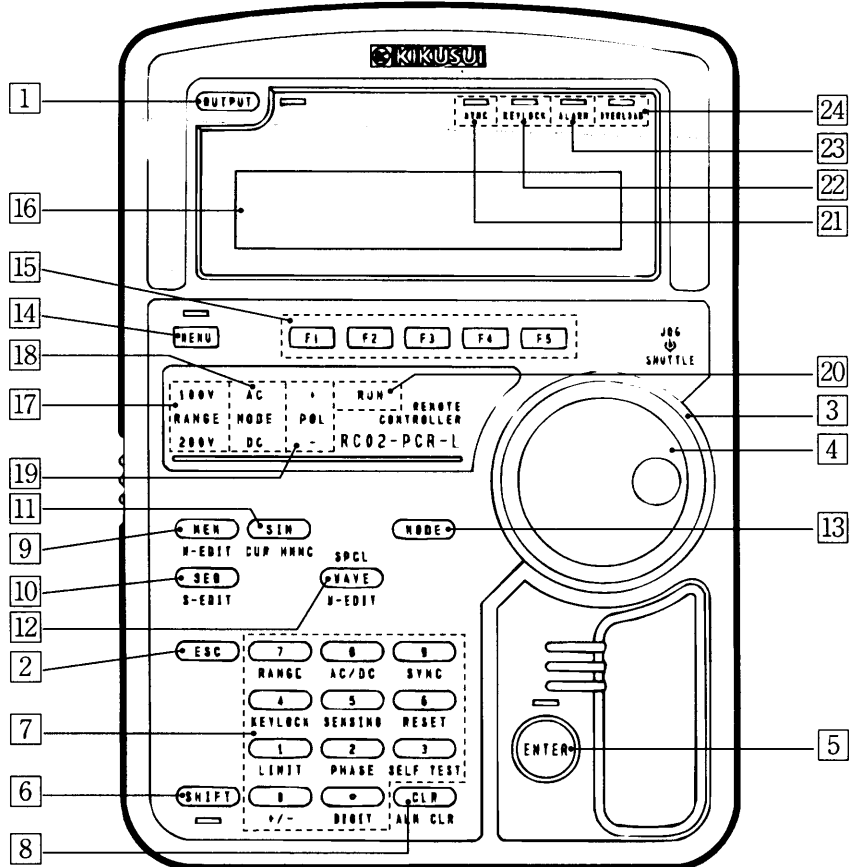

- 1 OUTPUT Selects output ON/OFF. (Whenever this switch is pressed, output ON/OFF is switched alternately.) When output is ON, the LED at the right of the key lights up. Immediately after the POWER switch of the PCR-W is turned ON, output is OFF.
- 2 ESC Used to end or cancel each operation.
- 3 JOG Used to set voltage, frequency, and other parameters. This is a rotary encoder with 10 clicks per rotation. The encoder increases the set value when it is turned clockwise; it decreases the set value when it is turned counterclockwise.
- 4 SHUTTLE Used to set voltage, frequency, and other parameters. You can choose from among four levels by setting the change speed, which varies with the angle to which the SHUTTLE is turned. The set value increases when the SHUTTLE is turned clockwise; it decreases when the SHUTTLE is turned counterclockwise.
- 5 ENTER Establishes the key operation. The LED above this key blinks during ENTER wait. This key has the same function as ENT on the PCR-W AC Power Supply control panel.
- 6 SHIFT Enables the function set in blue letters below each key. If SHIFT is pressed, the LED below this key lights up.
- 7 0, 1, 2, 3, 9 (numeric keys) and ". ."
 - Used to directly enter the voltage, current and frequency values. (".": Decimal point)
 - An input value is established when ENTER is pressed. It is canceled if ESC or CLR is pressed.

SHIFT + 0 (+/-)

Switches polarity of the DC mode voltage (+/-).

SHIFT + 1 (LIMIT)

Selects the limit value display mode for voltage, frequency, and current.

SHIFT + 2 (PHASE) [Available at the PCR-W² Series is used in three-phase mode]

Used to select either phase voltage or line voltage display mode or to select either output phase voltage or output line voltage for display in the voltage display area.
Used to select the output phase current for display in the current display area.

SHIFT + 3 (SELFTTEST)

Selects the self-test mode in the event of an alarm or overload.

SHIFT + 4 (KEYLOCK)

Selects the key lock mode.

In the key lock mode, KEYLOCK lights up, and all keys except OUTPUT and SHIFT + 4 (KEYLOCK) are disabled.

SHIFT + 5 (SENSING)

Selects the sensing mode.

To set the sensing mode, connect the sense wires to the sensing terminals, set the voltage, and press SHIFT + 5. The sensing mode allows no voltage change.

SHIFT + 6 (RESET)

Reset all set values (including those in the PCR-W AC Power Supply memory). When a reset is performed, all set values return to their Initial Setup Status (factory shipment status).

- A reset can be established by pressing SHIFT + ENTER.

SHIFT + 7 (RANGE)

Selects output voltage range.

The "100V" indication in the RANGE area lights up when equipment is in the 100V range, "200V" lights up when it is in the 200V range.

- When SHIFT + 7 is pressed, the range indication to be selected blinks. Press ENTER to establish the mode selection.

SHIFT + 8 (AC/DC)

Switches the mode among the AC, DC, and AC + DC modes.

The "AC" indication in the MODE area lights up in the AC mode, "DC" lights up in the DC mode, and both "AC" and "DC" light up in the AC + DC mode.

- When SHIFT + 8 is pressed, the mode to be selected blinks. Press ENTER to establish the mode selection.

SHIFT + 9 (SYNC)

Currently not used.

SHIFT + . (DIGIT)

Selects the digit mode that enables a specified or higher digits to change in the voltage setting or frequency setting mode.

In the digit mode, the cursor (under bar) blinks below the digit to change in the LCD's voltage or frequency display area, thereby allowing the relevant digit and higher digits (left of the relevant digit) to be changed.

- 8 CLR** Cancels the set value and recalls the previous value.

SHIFT + CLR (ALMCLR)

Clears the alarm status in the event of an alarm.

- 9 MEM** Calls voltage (and frequency) value (or values) from the memory.
- Pressing MEM and then selecting a memory address using the numeric keys or JOG/SHUTTLE will call the address and the voltage (and frequency) value (or values) stored in that address on the LCD.
 - Press ENTER to set the called voltage (and frequency).

SHIFT + MEN (M-EDIT)

Stores the voltage (and frequency) value (or values) in the memory.

Set the voltage (and frequency) you wish to store and the relevant address, then press ENTER. This will store the value (or values) in the memory.

- 10 SEQ** Currently not used.

SHIFT + SEQ (S-EDIT)

Currently not used.

- 11 SIM Currently not used.

SHIFT + SIM (CUR HMNC)

Currently not used.

- 12 WAVE Currently not used.

SHIFT + WAVE (W-EDIT)

Currently not used.

- 13 MODE Allows switching of output ON/OFF phase, and regulation adjustment.

- 14 MENU Selects the next display if there are two or more displays.

SHIFT + MENU

Selects the previous screen if there are two or more displays.

- 15 F1, F2, F3, F4, F5 (function keys)
Used to select the items displayed on the LCD.

- 16 Liquid Crystal Display (LCD)
A display unit with backlight.

- 17 RANGE indication
Displays the output voltage range.
"100V" lights up above the RANGE indication for the 100V range; "200V" lights up for the 200V range.

- 18 MODE indication
Displays the output voltage mode.
"AC" lights up in the AC mode, "DC" in the DC mode, and both "AC" and "DC" in the AC + DC mode.

- 19 POL indication
Currently not used.

- 20 RUN indication
Currently not used.

- 21 SYNC indication
Currently not used.

- 22 KEYLOCK indication
Lights up in the key-lock mode.

23 ALARM indication

In the event of alarm, this indication blinks, and an intermittent buzzer tone sounds.

24 OVERLOAD indication

Lights in the event of an overload (over current).

If the overload continues for a few seconds, output goes OFF. This generates an alarm and sounds intermittent buzzer tones.

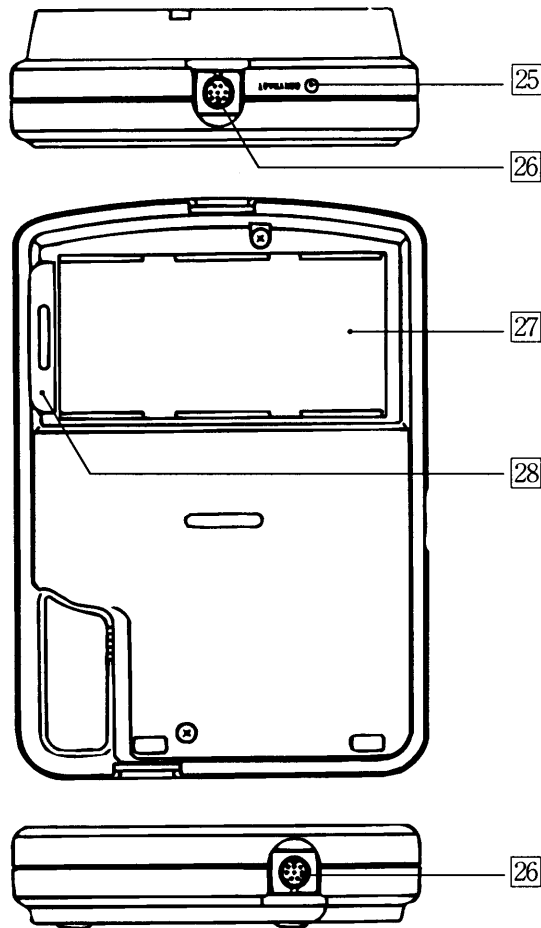

25 Contrast Used to adjust the brightness of text displayed on the LCD.

26 8-contacts mini-plug connectors.
Used for connecting the remote controller cable. Use one of these connectors.

27 Magnet sheet attachment area
The provided magnet sheet is attached here. Use of the magnet sheet allows the remote controller box to stick on the side of a PCR-W AC Power Supply or other vertical steel surface.

28 Quick reference card
Briefly describes keys and simulation waveforms. (The PCR-W and PCR-W² Series do not have a simulation function.)

Chapter 7

MAINTENANCE

Describes the solutions in the event of a problem. Always read this chapter before requesting a repair.

Contents

7.1 Before Requesting a Repair	7-2
--------------------------------------	-----

7.1 Before Requesting a Repair

If a problem occurs in the RC02-PCR-L, check that problem in accordance with the following table. Also, disconnect the Remote Controller from the PCR-W AC Power Supply and check if the power supply alone operates normally. If it is not possible to recover a normal status, contact your Kikusui agent to request repairs.

Problem	Check item	Results	Possible causes
LCD display does not appear, or display content is not normal.	Check if the remote controller card is correctly inserted into a slot.	NO	Improper remote controller card installation (see 2.3)
	Check if the remote controller cable is correctly connected.	NO	Improper remote controller cable connection (see 2.4)
	Check the contrast adjustment.	NO	Improper contrast adjustment (see 3.1)
The Remote Controller cannot be operated.	Check if the remote controller card is correctly inserted into a slot.	NO	Improper remote controller card installation (see 2.3)
	Check if the remote controller cable has been correctly connected.	NO	Improper remote controller cable connection (see 2.4)
	Check if the PCR-W AC Power Supply is in the key-lock mode.	NO	Operation via the Remote Controller is invalid. (Countermeasure: Press SHIFT + 4 (KEYLOCK) on the PCR-W Power Supply control panel.)

Chapter 8

SPECIFICATIONS

List the specifications.

Contents

8.1 Specifications	8-2
8.2 Dimensions	8-2

8.1 Specifications

Item	Setting range	Resolution	Setting accuracy
AC + DC mode			
Voltage setting	AC voltage setting range is the same as that of PCR-W's AC mode. DC voltage setting range is the same as that of PCR-W's DC mode. However, the peak value for AC + DC voltage should be within the DC voltage setting range.	Same as PCR-W's AC mode and same as PCR-W's DC mode	—
Maximum current	Same as PCR-W's DC mode	—	—
Power capacity	Same as PCR-W's DC mode	—	—
Frequency	Same as PCR-W's AC mode	Same as at the left	—
Output ON/OFF phase setting	0 deg to 360 deg	1 deg	1 deg
Indicator			
Voltampere measurement	—	0.01 VA min. (changes with VA value)	Same as wattmeter of PCR-W
Power-factor measurement	—	0.01	Same as wattmeter of PCR-W
Peak holding current measurement	—	Same as peak ammeter of PCR-W	Within $\pm(2\%$ of r.d.g + 16 d) (from 5% of max. rated current to max. rated peak current at normal temperature)

8.2 Dimensions

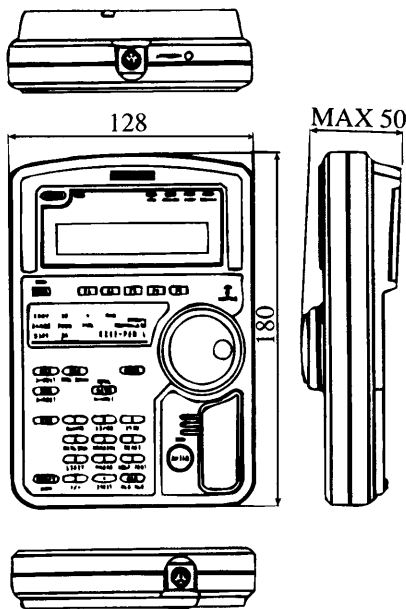

Remote controller box

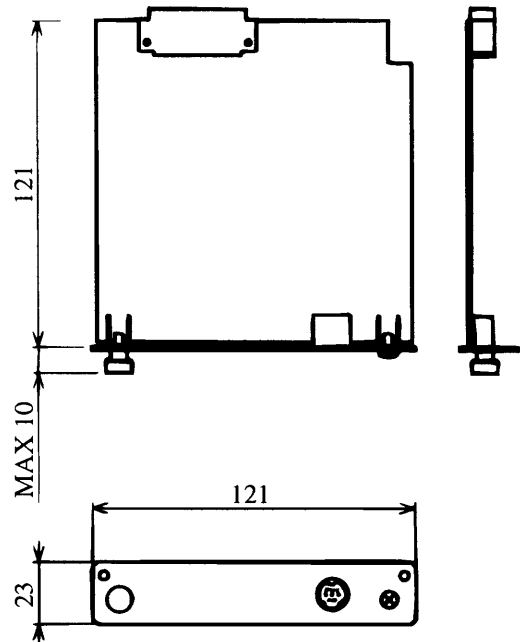

Remote controller card

Unit: mm

APPENDIX

Shows the hierarchy of the key operation menu.

Contents

Hierarchy of Remote Controller Key Operating Menus	A-2
(1) Hierarchy of Voltage, Current, Frequency and Other Factor Setting and Display Operating Menus	A-2
(2) Hierarchy of Memory Operating Menu	A-4
(3) Hierarchy of Special Function Operating Menu	A-6

Hierarchy of Remote Controller Key Operating Menus

(1) Hierarchy of Voltage, Current, Frequency and Other Factor Setting and Display Operating Menus

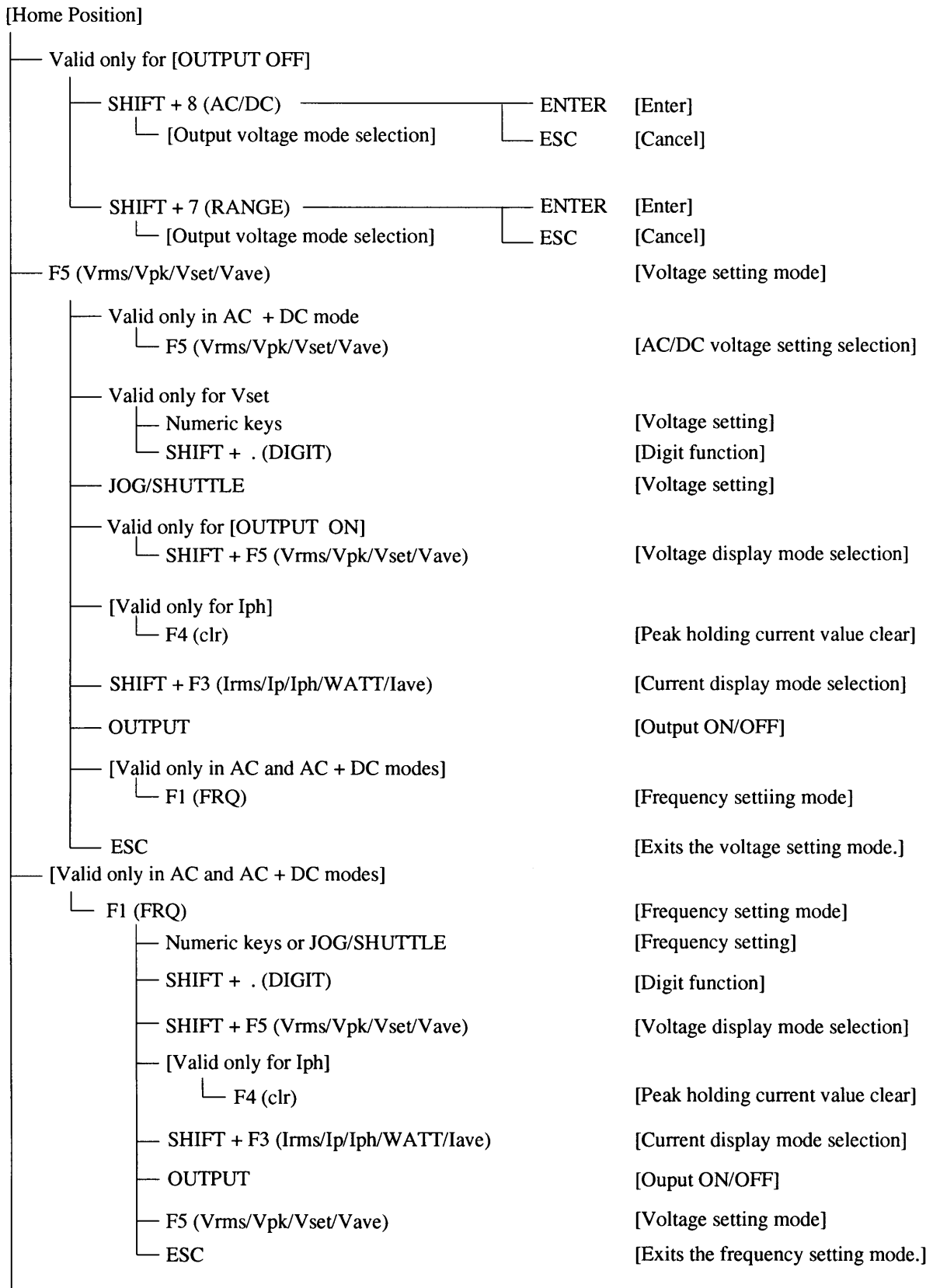

—SHIFT + 1 (LIMIT)	[Limit value display mode]
—SHIFT + 1 (LIMIT)	[Limit value display selection (HIGH/LOW)]
—MENU [Valid only in AC and AC + DC modes]	[Limit value display selection (HIGH/LOW)]
└─ F5 (Vmax/Vmin)	[Voltage limit setting mode]
└─ Numeric keys or JOG/SHUTTLE	[Voltage limit setting]
└─ [Valid only in AC mode]	
└─ F1 (Fmax/Fmin)	[Frequency limit setting mode]
└─ Valid only for [HIGH/LIMIT indication]	
└─ F3 (Imax)	[Current limit setting mode]
└─ SHIFT + 1 (LIMIT)	[Limit value display selection (HIGH/LOW)]
└─ MENU	[Limit value display selection (HIGH/LOW)]
└─ OUTPUT	[Output ON/OFF]
└─ ESC	[Exits the voltage limit setting mode.]
└─ [Valid only in AC mode]	
└─ F1 (Fmax/Fmin)	[Frequency limit setting mode]
└─ Numeric keys or JOG/SHUTTLE	[Frequency limit setting]
└─ F5 (Vmax/Vmin)	[Voltage limit setting mode]
└─ Valid only for [HIGH LIMIT indication]	
└─ F3 (Imax)	[Current limit setting mode]
└─ SHIFT + 1 (LIMIT)	[Limit value display selection (HIGH/LOW)]
└─ MENU	[Limit value display selection (HIGH/LOW)]
└─ OUTPUT	[Output ON/OFF]
└─ ESC	[Exits the voltage limit setting mode.]
└─ [Valid only for [HIGH LIMIT indication] in AC and DC modes]	
└─ F3 (Imax)	[Current limit setting mode]
└─ Numeric keys or JOG/SHUTTLE	[Current limit setting]
└─ F5 (Vmax)	[Voltage limit setting mode]
└─ [Valid only in AC mode]	
└─ F1 (Fmax)	[Exits the limit value display mode]
└─ OUTPUT	[Frequency limit setting mode]
└─ ESC	[Output ON/OFF]
└─ ESC	[Exits the current limit setting mode.]
└─ [Valid only for Iph]	
└─ F4 (clr)	[Exits the limit value display mode.]
—OUTPUT	[Peak holding current value clear]
—SHIFT + F5 (Vrms/Vpk/Vset/Vave)	[Output ON/OFF]
—SHIFT + F3 (Irms/Ip/Iph/WATT/Iave)	[Voltage display mode selection]
—MENU	[Current display mode selection]
└─ OUTPUT	[Power, VA, and power-factor display mode]
└─ ESC	[Output ON/OFF]
└─ MENU	[Exits the power, VA, and power-factor display mode.]
	[Exits the power, VA, and power-factor display mode.]

(2) Hierarchy of Memory Operating Menu

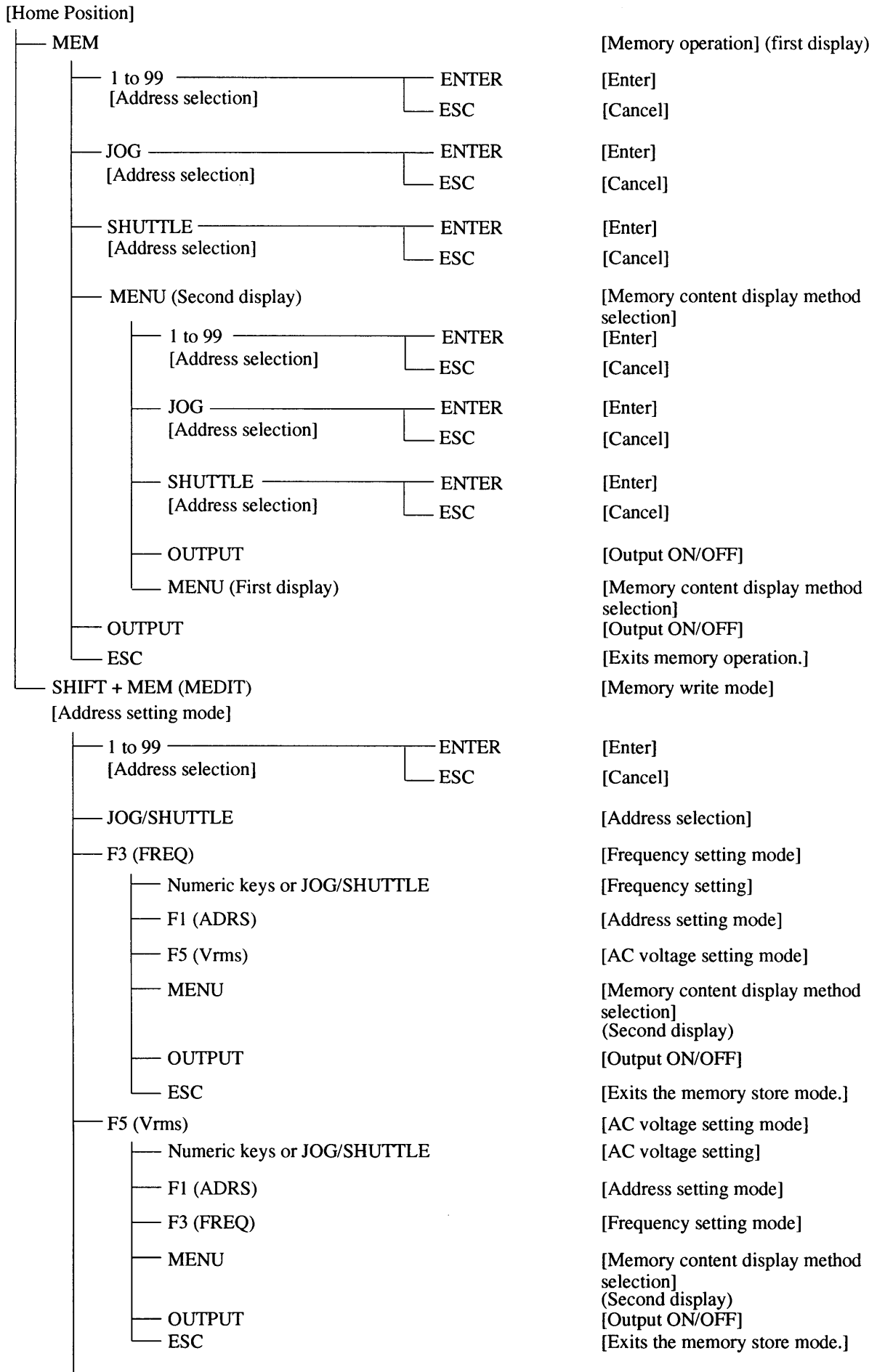

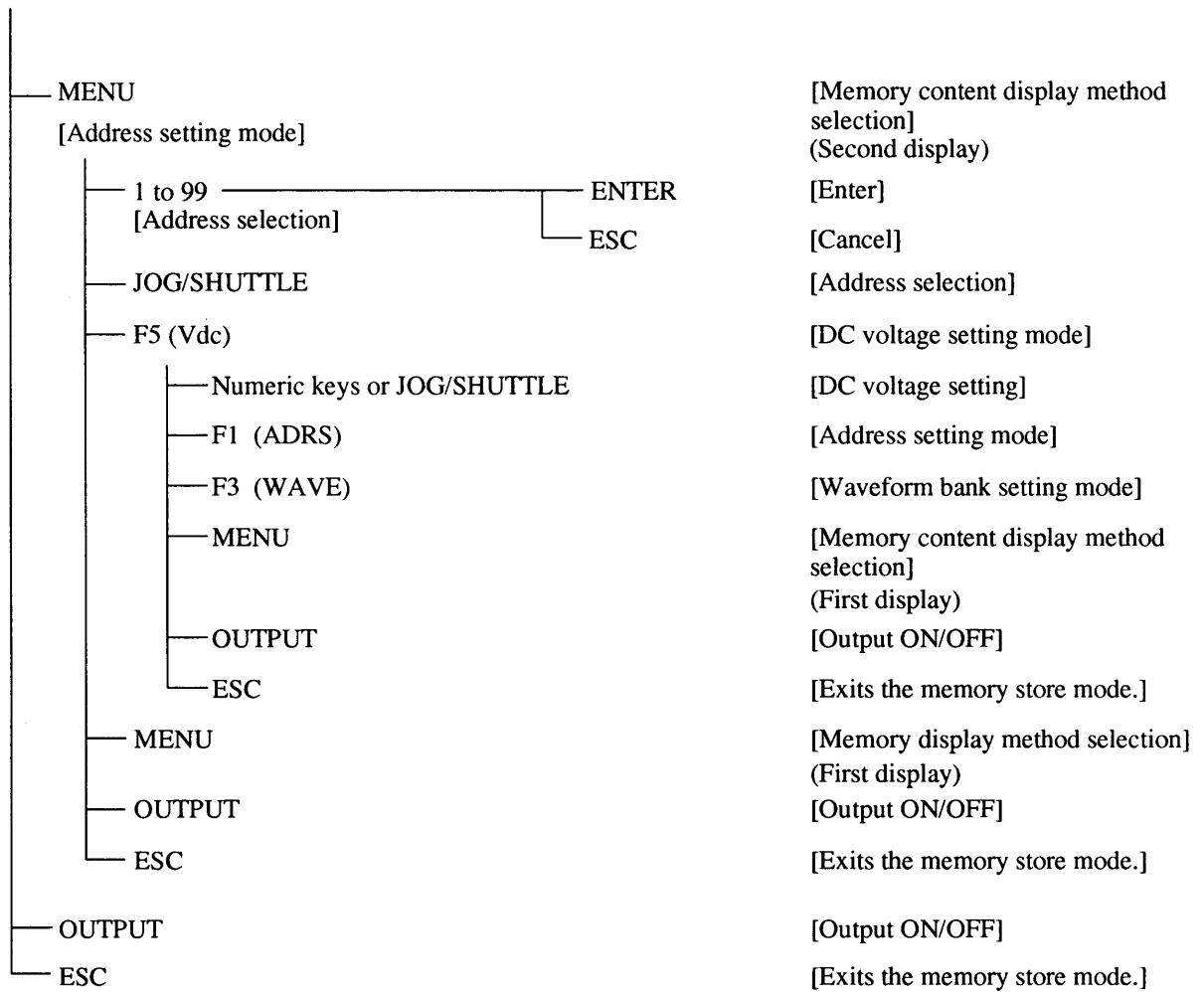

(3) Hierarchy of Special Function Operating Menu

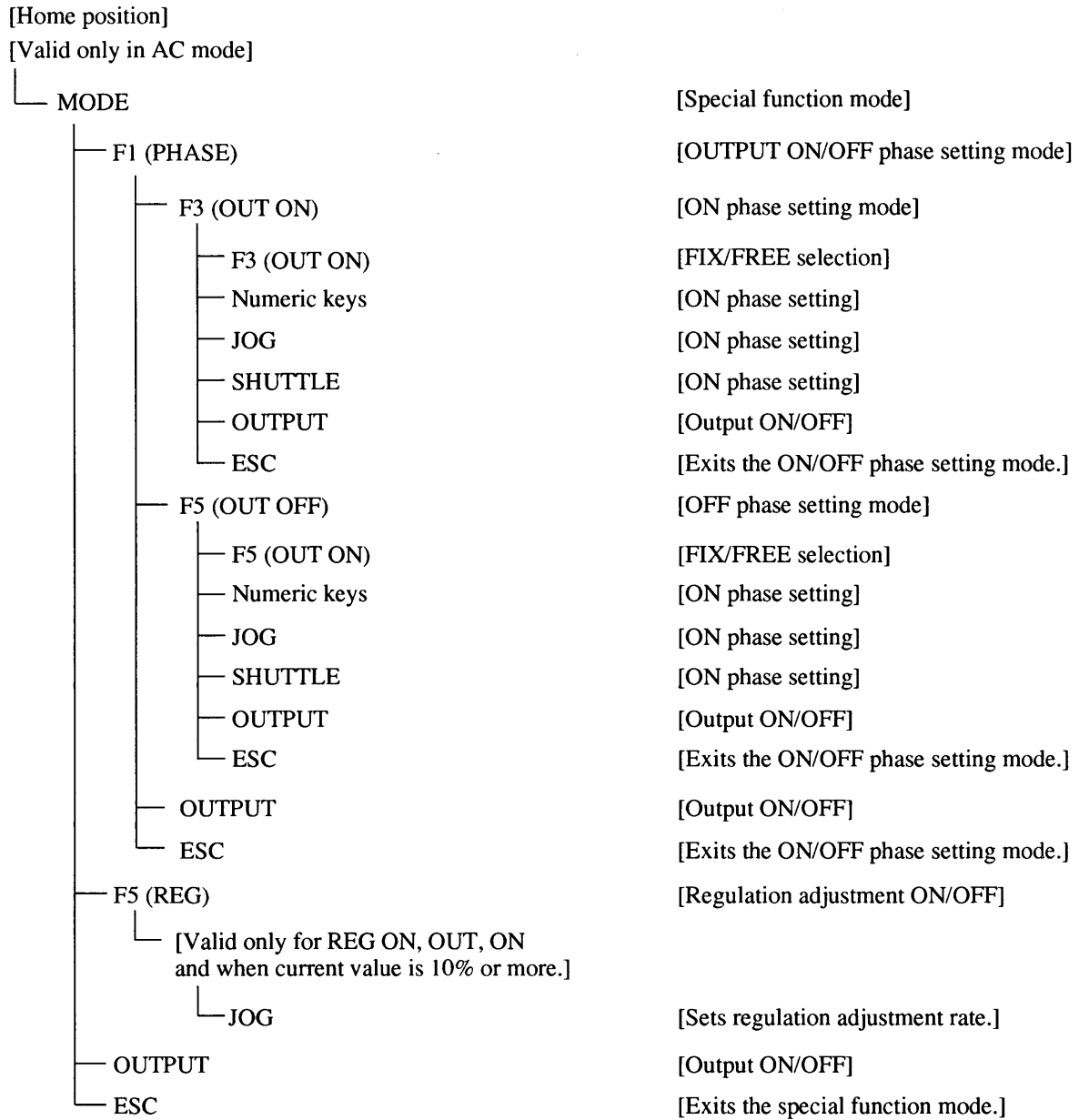

INDEX

A

- AC + DC mode 1-2, 4-4
- AC + DC voltage peak value 4-5

B

- Back-up data has been lost 3-4

E

- ENTER Wait 3-3

H

- Handling of remote controller box 2-3
- Handling of remote controller card 2-3
- Home Position 3-2
- How to Install the Remote Controller Card into a Slot . 2-4

I

- Initial Setup Status 3-2, 3-3, 4-8, 4-10, 6-4

L

- LCD Contrast Adjustment 3-3

M

- magnet sheet 2-5
- measurement of peak holding current 1-2
- measurement of power-factor 1-2
- measurement of VA 1-2
- memory function 1-2, 4-6
- Memory Read Procedure 4-8
- Memory Setting Procedure 4-6

O

- Operation Check Procedure 3-3
- Output ON/OFF phase setting 1-2, 4-10

P

- PCR-W2 AC Power Supplies 1-2, 5-2
- peak current value display 4-10
- peak holding current value display 4-10
- Peak holding value measurement 4-9
- Peak value measurement 4-9
- Power Display 4-8
- Power-Factor Display 4-8

R

- regulation adjustment 1-2, 4-11
- Resetting Procedure 3-2

T

- three-phase mode 1-2, 5-2

V

- Volt-ampere Display 4-8